



SMART ENERGY SOLUTIONS
 E-mail: sales@smartlednc.com
www.smartlednc.com

P/N: AST-PG06-75WBSP1SA1-abcWe

Note:

AST= Company name
 PG06 = Product series, LED Parking Garage Light
 75W = Rating Power
 "B"= Lumileds 2835 ,LED manufacturer,
 "SP1" = 160°Cover type,
 "S" =single color temperature, representing the Led Module type,
 "A1" = Version number,
 "a" can be any letters to represent Housing colors.
 "b" can be "P" or blank, "P" for Photocontrol, blank for no Photocontrol provided.
 "c" can be "M" or blank, "M" for microwave sensor, blank for no sensor provided.
 "W" represents for Wattage adjustable;
 "e" can be any digits or blank to represents CCT.
 can be 30=3000K, 35=3500K, 40=4000K, 45=4500K,
 50=5000K, 57=5700K

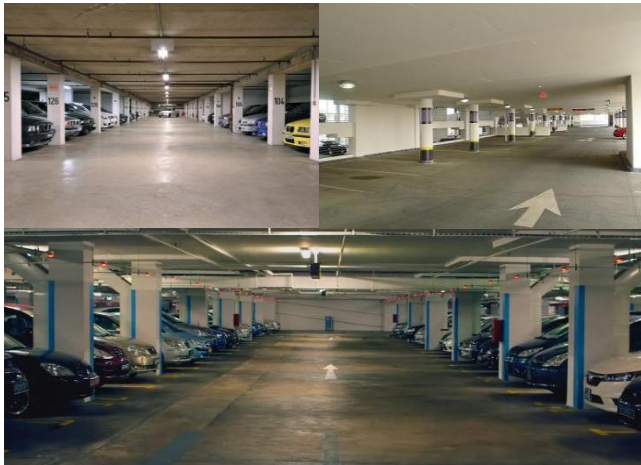

DIMENSIONS

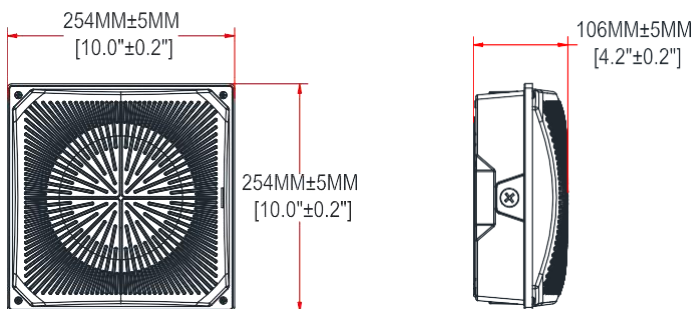

Advantage:

- UL cUL certificate.
- IP65 Internal driver, Input voltage 120-277Vac.
- No UV or IR in the beam.
- Easy to install and operate.
- Energy saving, Long lifespan.
- Light is soft and uniform, Safe to eyes.
- Instant start, NO flickering, NO humming.
- Green and eco-friendly without mercury.
- 0-10V Dimming.

Application:

- ◆ Widely used in gas station, service station, underground parking lot, warehouse, garage;
- ◆ Work floor, factory and so on.

SPECIFICATIONS

OPTICAL	Input Power (Tolerance : ±10%)	75W(Wattage Adjustable Range: 25%-100%)					
	Color Temperature	3000K	3500K	4000K	4500K	5000K	5700K
	Lumen (Tolerance : -10%)	9977 LM	10005 LM	10034 LM	10058 LM	10081 LM	10148 LM
	Efficacy (Tolerance : -3%)	137LM/W	139 LM/W	139LM/W	140 LM/W	140LM/W	142LM/W
	CRI	>80					
	Color Consistency	<6 Steps (or <6 SDCM)					
	BUG	B3-U3-G3					
	Diffuser Type	PC					
	Beam Angle (50%) (Tolerance : ±15%)	160 Degree					
ELECTRICAL	Input Voltage and Frequency	120-277VAC, 50/60Hz;					
	PF (Tolerance : -3%)	≥0.9					
	THD (Tolerance : +5%)	≤20%					
	Flicker Percent	<30%					
	Driver Brand	BECKY					
	Driver Model	BQE85-1580-43-PV					
	Driver Surge protection	L/N-PE: 6kV, L-N: 4kV					
	Dimming	0-10V dimming standard					
MATERIALS	LED Brand	Lumileds 2835					
	LED Type	SMD2835 (0.5W)					
	LED QTY	140 PCS					
	Housing	Die-cast aluminum					
	Housing Color	White, or Customized					
	Waterproof Rating	WET (IP65)					
OTHERS	Operating Temperature	-30°C TO +45°C					
	Storage Temperature	-30°C TO 85°C					
	Operating Humidity	20% - 90% RH					
	Storage Humidity	10%-95% RH					
	Warranty	5 years warranty with 24/7 operating hours Luminaire lifetime at 25°C.					

PACKAGE

	Size	Qty / Carton	Net Weight / Carton	Gross Weight / Carton
Inner box	308*158*310 mm	1 PCS	2.84 KG	3.46 KG
Outer box	332*323*330 mm	2 PCS	5.68 KG	7.638 KG

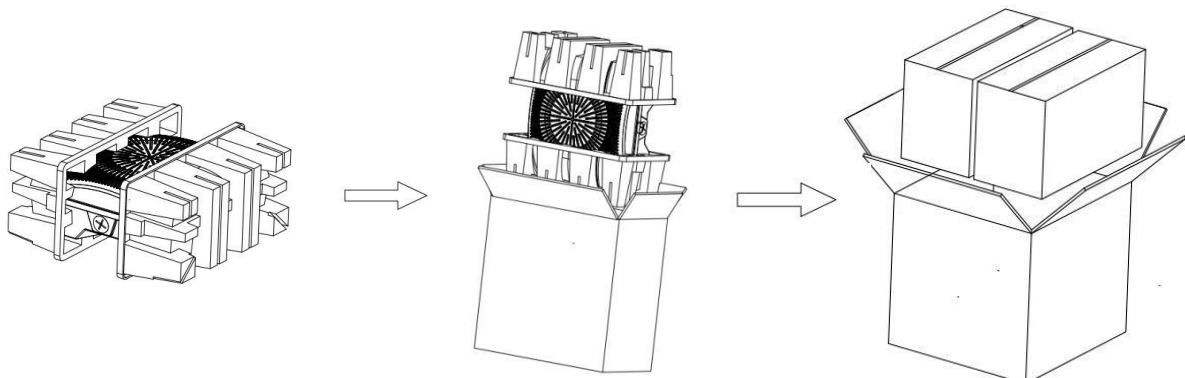

LIGHT DISTRIBUTION TESTING PARAMETERS**Notice For User**

- ◆ Please turn off power before install or change assembly parts.
- ◆ The input voltage and lamps should be matched, after connecting the power line, Please make sure the wiring section is insulated.
- ◆ No-professionals, must not install and disassemble the lamps.

Trouble Shootings

Troubles	Check points
Flickering of the light	Turn off the power and turn on again in 3 minutes. If same phenomena occur, then call agencies
Out of working	Please check the connection